

# Multicomponent Force Plate

Type 9286B...

Portable – for Applications in Biomechanics,  $F_z$  0 ... 10 kN

Portable multicomponent force plate with aluminum top plate for measuring ground reaction forces, moments and the center of pressure in biomechanics.

- Excellent accuracy of center of pressure (COP)
- Very wide measuring range
- Easy mounting
- Flexible, mobile application
- Threshold  $F_z < 250$  mN

## Description

Rather than conventional frame mounted force plates, the multicomponent force plate Type 9286B... can simply be used on any flat surface. This drastically cuts installation costs. The plate's low overall height of just 35 mm and weight of under 18 kg allows flexible, portable use.

The piezoelectric 3-component force sensors have very low crosstalk values and in conjunction with the special design principle ensure excellent accuracy of the center of pressure.

## Application

This force plate is designed specifically for use in gait and balance analyses. The Type 9286BA has a built-in charge amplifier compatible with all of the common motion analysis systems. Despite the very wide measuring range (0 ... 10 kN), this force plate offers excellent accuracy and linearity over the entire spectrum of applications (4 measuring ranges) and guarantees overload protection up to 12 kN.



## Technical Data

Dimensions		mm	600x400x35
Measuring range	$F_x, F_y$	kN	-2,5 ... 2,5
	$F_z$	kN	0 ... 10
Overload	$F_x, F_y$	kN	-3/3
	$F_z$	kN	0/12
Linearity		%FSO	$< \pm 0,2$
Hysteresis		%FSO	$< 0,3$
Crosstalk	$F_x \leftrightarrow F_y$	%	$< \pm 1,5$
	$F_x, F_y \rightarrow F_z$	%	$< \pm 2,0$
	$F_z \rightarrow F_x, F_y$	%	$< \pm 0,5^{1)}$
Rigidity	x-axis ( $a_y = 0$ )	N/ $\mu$ m	$\approx 12$
	y-axis ( $a_x = 0$ )	N/ $\mu$ m	$\approx 12$
	z-axis ( $a_x = a_y = 0$ )	N/ $\mu$ m	$\approx 8$
Natural frequency	$f_n (x, y)$	Hz	$\approx 350$
	$f_n (z)$	Hz	$\approx 200$
Operating temperature range		$^{\circ}$ C	0 ... 60
Weight		kg	17,5
Degree of protection	EN 60529:1992		IP52/IP63 <sup>2)</sup>

## Force Plate without Charge Amplifier, Type 9286B

Calibrated range	$F_x, F_y$	kN	-2,5 ... 2,5
	$F_z$	kN	0 ... 5
Calibrated partial range	$F_x, F_y$	kN	0 ... 0,25
	$F_z$	kN	0 ... 1
Threshold	$F_x, F_y, F_z$	mN	$< 10$
Sensitivity	$F_x, F_y$	pC/N	-7,8 <sup>3)</sup>
	$F_z$	pC/N	-3,6 <sup>3)</sup>

<sup>1)</sup> inside sensor rectangle

<sup>2)</sup> Type 9286B with charge output IP63

<sup>3)</sup> nominal value

**Force Plate with Built-in 8 Channel Charge Amplifier, Type 9286BA**

Calibrated range 3	F <sub>x</sub> , F <sub>y</sub>	kN	-2,5 ... 2,5
	F <sub>z</sub>	kN	0 ... 10
Calibrated partial range	F <sub>x</sub> , F <sub>y</sub>	kN	0 ... 0,25
	F <sub>z</sub>	kN	0 ... 1
Sensitivity range 1	F <sub>x</sub> , F <sub>y</sub>	mV/N	≈40 <sup>3)</sup>
	F <sub>z</sub>	mV/N	≈18 <sup>3)</sup>
Sensitivity range 4	F <sub>x</sub> , F <sub>y</sub>	mV/N	≈2,0 <sup>3)</sup>
	F <sub>z</sub>	mV/N	≈0,9 <sup>3)</sup>
Ratio ranges 1:2:3:4			1 : 5 : 10 : 20 <sup>4)</sup>
Threshold		mN	<250 <sup>5)</sup>
Drift		mN/s	<±10
Supply voltage		V DC	10 ... 30
Supply current		mA	≈45

Output voltage	V	0 ... ±5
Output current	mA	-2 ... 2
Control inputs (optocoupler)	V	5 ... 45
	mA	0,4 ... 4,4

- 3) nominal value
- 4) ±0,5 % accuracy
- 5) only range 1

Conforms to the CE safety standards (73/23/EG) for electrical equipment and systems:

EN 60601-1:2005, EN 61010-1:2001  
and the EMC standards (89/336/EG):  
EN 60601-1:2005 (EN 55022 Class B), EN 61000-6-3:2004  
(EN 55022 Class B), EN 61000-6-4:2001 (EN 55011 Class B),  
EN 60601-1:2005, EN 61000-6-1:2001, EN 61000-6-2:2005

**Dimensions**

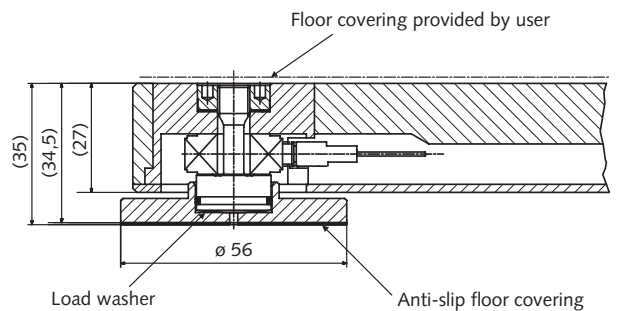
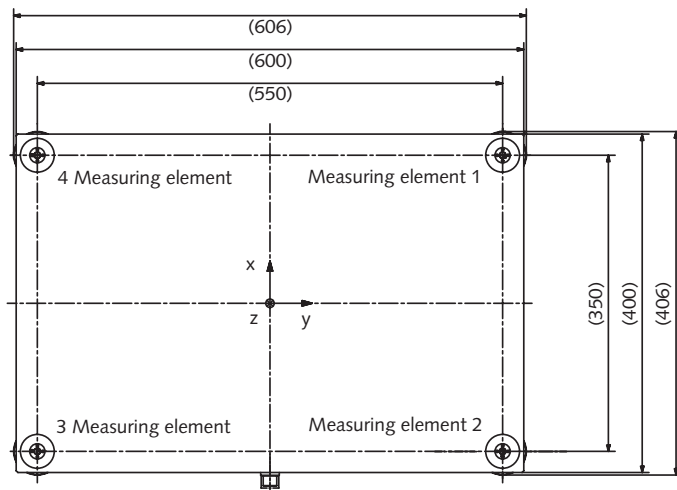

Fig. 1: Dimensions of portable multicomponent force plate Type 9286BA

**Walkway Type 9401B...**

Four different lightweight sandwich elements are available for assembling a walkway of any length with various arrangements of force plates. An anti-slip floor covering provides safety on the walkway as well as on the force plate.

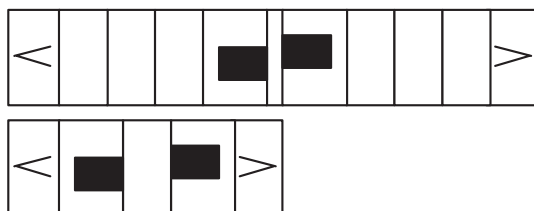
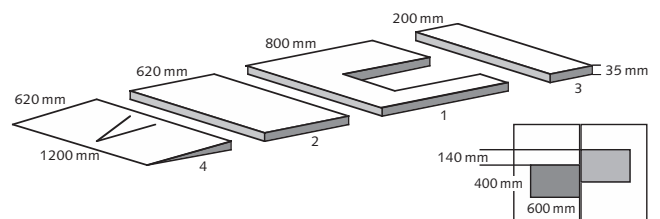

Fig. 2: Mounting examples

Walkway:  
1 = Type 9401B01, 2 = Type 9401B02, 3 = Type 9401B03,  
4 = Type 9401B04

9286B\_000-713e-09.08

**BioWare®**

BioWare software is the engine behind the force plate system. It collects data from the force plates, converts the trials into useful information and plots the results. The force plates and charge amplifiers are fully remote controlled by BioWare thus making the system extremely flexible and easy-to-use.

**Parameters of Gait**

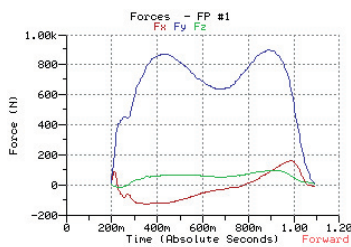

Fig. 3: Ground reaction forces (GRF)

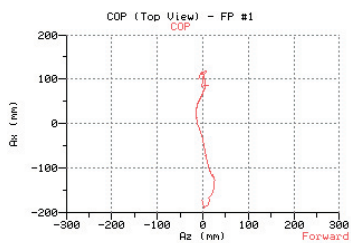

Fig. 4: Center of pressure (COP)

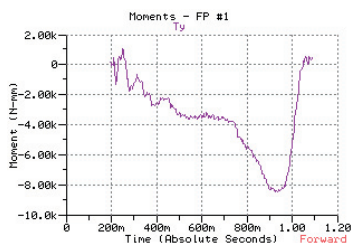

Fig. 5: Frictional torque  $T_z$

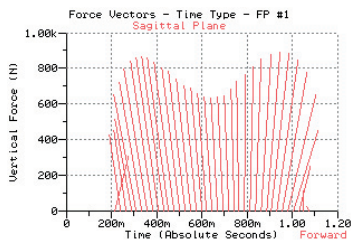

Fig. 6: Force vector

**Other functions**

- Coefficient of friction (COF)
- Frequency analysis, statistics, digital filters
- Full Windows® functionality

Windows® is a registered trade mark of Microsoft Corporation.

This information corresponds to the current state of knowledge. Kistler reserves the right to make technical changes. Liability for consequential damage resulting from the use of Kistler products is excluded.

BioWare provides several performance specific evaluations.

**Parameters of Countermovement Jump CMJ**

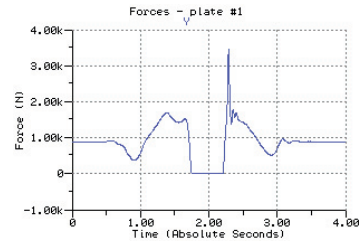

Fig. 7: Jump force

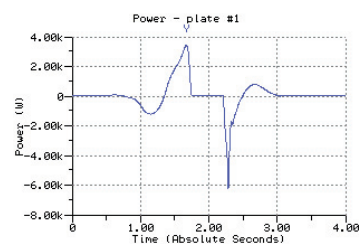

Fig. 8: Power

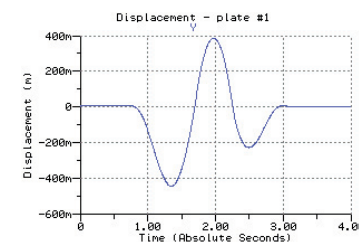

Fig. 9: Jump height (COM)

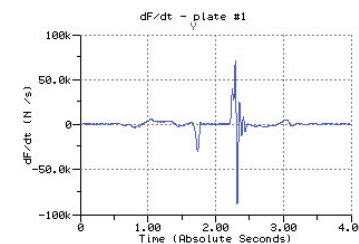

Fig. 10: Force gradient (Explosivity)

**Other parameters**

- Acceleration, velocity and displacement of the center of mass (COM)
- Work, energy, impulse
- Statistics, digital filters

9286B\_000-713e-09.08

**Typical Measuring Chains**



			
Force plate with built-in charge amplifier Type 9286BA	Connection cable Type 1758A...	DAQ system (USB 2.0) Type 5691A1	Laptop (provided by user) with BioWare

Fig. 11: Configuration of a typical measuring chain with Kistler DAQ system BioWare®



			Ch 1 = F <sub>x</sub> 1+2    Ch 5 = F <sub>z</sub> 1 Ch 2 = F <sub>x</sub> 3+4    Ch 6 = F <sub>z</sub> 2 Ch 3 = F <sub>y</sub> 1+4    Ch 7 = F <sub>z</sub> 3 Ch 4 = F <sub>y</sub> 2+3    Ch 8 = F <sub>z</sub> 4
Force plate with built-in charge amplifier Type 9286BA	Connection cable Type 1760A...	External Control Unit (8xBNC neg.) Type 5233A2	DAQ system provided by user (8 analog channels)

Fig. 12: Configuration of a typical measuring chain

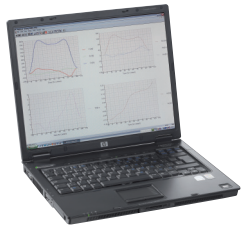
**Included Accessories**

- 1 shim set
- 1 voltage equalizing cable

**Type/Art. No.**

7.050.031  
5.590.175

**Ordering Key**

<b>Portable Multicomponent Force Plate</b>	
with charge output	–
with built-in charge amplifier	A

Type 9286B

**Optional Accessories**

**For Type 9286BA with built-in charge amplifier**

- Connection cable, straight plug 1758A...
- Connection cable, angle plug 1759A...
- DAQ-System for BioWare (USB 2.0) 5691A1
- External Control Unit (BNC out) 5233A2
- Connection cable, straight for Type 5233A... 1760A...
- Connection cable, angled for Type 5233A... 1757A...
- DAQ system BioWare (PCI-Bus) 2812A...

**For Type 9286B with charge output**

- External charge amplifier 9865E...
- Connection cable, straight plug 1685B...
- Connection cable, angle plug 1686A...
- DAQ system for BioWare (PCI-Bus) 2812A...

**For Type 9286B...**

- Walkway, central piece 9401B01
- Walkway, extension 9401B02
- Walkway, intermediary piece 9401B03
- Walkway, ramp 9401B04

BioWare® is a registered trade mark of Kistler Holding AG.

9286B\_000-713e-09.08